

**UNITED STATES DISTRICT COURT
SOUTHERN DISTRICT OF NEW YORK**

DR. JOHN THOMAS FRIEDLAND,

Docket No.: 1:24-cv-01216

Plaintiff,

- against -

**COMPLAINT AND DEMAND FOR
JURY TRIAL**

SENSIO, INC.,

Defendant.

COMPLAINT

Plaintiff, by and through his attorneys, **JOHNSON BECKER, PLLC** and **MILBERG COLEMAN BRYSON PHILLIPS GROSSMAN, LLC**, upon information and belief, at all times hereinafter mentioned, alleges as follows:

NATURE OF THE CASE

1. Defendant Sensio, Inc. (“Defendant Sensio”) designs, manufactures, markets, imports, distributes, and sells a wide range of consumer kitchen products, including the subject “Bella Multi Cooker,” which specifically includes the Model Number M-80B23G (referred to hereafter as “pressure cooker(s)”) that is at issue in this case.
2. Defendant Sensio touts the “safety” of its pressure cookers, boasting that its pressure cookers feature a “floating pressure safety valve” that “will not go down until pressure is released and you will not be able to open the lid.”¹
3. Despite Defendant’s claims of “safety,” it designed, manufactured, marketed, imported, distributed and sold, both directly and through third-party retailers, a product that suffers from

¹ See Model Number M-80B23G at pg. 9. A copy is attached hereto at “Exhibit A”.

serious and dangerous defects. Said defects cause significant risk of bodily harm and injury to its consumers.

4. Specifically, said defects manifest themselves when, despite Defendant's statements, the lid of the pressure cooker is removable with built-up pressure, heat and steam still inside the unit. When the lid is removed under such circumstances, the pressure trapped within the unit causes the scalding hot contents to be projected from the unit and into the surrounding area, including onto the unsuspecting consumers, their families and other bystanders. Plaintiff was able to remove the lid while the pressure cooker retained pressure, causing Plaintiff serious and substantial bodily injuries and damages.

5. On August 10th, 2023, the Consumer Products Safety Commission ("CPSC") announced a recall of more than 860,000 of Defendants' pressure cookers, which includes the subject pressure cooker, after receiving "63 reports of incidents, **including 61 burn injuries**, some of which involved **second and third degree burns to the face, torso, arms, and hands.**"²

6. Defendant knew or should have known of these defects but have nevertheless put profit ahead of safety by continuing to sell its pressure cookers to consumers, failing to warn said consumers of the serious risks posed by the defects, and failing to timely recall the dangerously defective pressure cookers regardless of the risk of significant injuries to Plaintiff and consumers like him.

7. Defendant ignored and/or concealed its knowledge of these defects in its pressure cookers from Plaintiff in this case, as well as the public in general, in order to continue generating a profit

² See <https://www.cpsc.gov/Recalls/2023/Sensio-Recalls-Bella-Bella-Pro-Series-Cooks-and-Crux-Electric-and-Stovetop-Pressure-Cookers-Due-to-Burn-Hazard> (last accessed February 9, 2024)

from the sale of said pressure cookers, demonstrating a callous, reckless, willful, depraved indifference to the health, safety and welfare of Plaintiff and others like him.

8. As a direct and proximate result of Defendant's conduct, Plaintiff incurred significant and painful bodily injuries, medical expenses, physical pain, mental anguish, and diminished enjoyment of life.

DR. JOHN THOMAS FRIEDLAND

9. Plaintiff, Dr. Friedland, is a resident and citizen of the city of Little Rock, County of Pulaski, State of Arkansas. Plaintiff is therefore, a citizen of the State of Arkansas for purposes of diversity jurisdiction as prescribed by 28 U.S.C. § 1332.

10. On or about July 30, 2023, Plaintiff suffered serious and substantial burn injuries as the direct and proximate result of the Pressure Cooker's lid being able to be rotated and opened while the Pressure Cooker was still under pressure, during the normal, directed use of the Pressure Cooker, allowing its scalding hot contents to be forcefully ejected from the Pressure Cooker and onto Plaintiff. The incident occurred as a result of the failure of the Pressure Cooker's supposed "safety" features, which purport to keep the consumer safe while using the Pressure Cooker. In addition, the incident occurred as the result of Defendant's failure to redesign the Pressure Cooker, despite the existence of economical, safer alternative designs.

DEFENDANT SENSIO, INC.

11. Defendant designs, manufactures, markets, imports, distributes and sell a variety of consumer kitchen products including pressure cookers, air fryers, and pressure cookers, amongst others.

12. Defendant Sensio is a New York corporation with its principal place of business at 261 Madison Avenue, 25th Floor, New York, NY 10016. Defendant is, therefore, a citizen of the State of New York for purposes of diversity jurisdiction as prescribed by 28 U.S.C. § 1332.

JURISDICTION AND VENUE

13. This Court has subject matter jurisdiction over this case pursuant to diversity jurisdiction prescribed by 28 U.S.C. § 1332 because the matter in controversy exceeds the sum or value of \$75,000, exclusive of interest and costs, and there is complete diversity between the parties.

14. Venue is proper in this Court pursuant to 28 U.S.C. § 1391 because Defendant is a resident and citizen of this district.

15. Venue is also proper in this Court pursuant to 28 U.S.C. § 1391 because Defendant has sufficient minimum contacts with the State of New York and intentionally avails itself of the markets within New York through the promotion, sale, marketing, and distribution of their products.

FACTUAL BACKGROUND

16. Defendant is engaged in the business of designing, manufacturing, warranting, marketing, importing, distributing, and selling the pressure cookers at issue in this litigation.

17. Defendant Sensio touts the “safety” of its pressure cookers, boasting that its pressure cookers feature a “floating pressure safety valve” that “will not go down until pressure is released and you will not be able to open the lid.”³

18. By reason of the forgoing acts or omissions, Plaintiff used the pressure cooker with the reasonable expectation that it was properly designed and manufactured, free from defects of any kind, and that it was safe for its intended, foreseeable use of cooking.

19. Plaintiff used the pressure cooker for its intended purpose of preparing meals and did so in a manner that was reasonable and foreseeable by the Defendant.

³ *Id.*

20. However, the aforementioned pressure cooker was defectively and negligently designed and manufactured by the Defendant in that it failed to properly function as to prevent the lid from being removed with normal force while the unit remained pressurized, despite the appearance that all the pressure had been released, during the ordinary, foreseeable and proper use of cooking food with the product; placing the Plaintiff, his family, and similar consumers in danger while using the pressure cookers.

21. Defendant's pressure cookers possess defects that make them unreasonably dangerous for their intended use by consumers because the lid can be rotated and opened while the unit remains pressurized.

22. Further, Defendant's representations about "safety" are not just misleading, they are flatly wrong, and put innocent consumers like Plaintiff directly in harm's way.

23. Economic, safer alternative designs were available that could have prevented the Pressure Cooker's lid from being rotated and opened while pressurized.

24. Defendant knew or should have known that its pressure cookers possessed defects that pose a serious safety risk to Plaintiff and the public. Nevertheless, Defendant continues to ignore and/or conceal its knowledge of the pressure cookers' defects from the general public and continues to generate a substantial profit from the sale of their pressure cookers, demonstrating a callous, reckless, willful, depraved indifference to the health, safety and welfare of Plaintiff and others like him.

25. As a direct and proximate result of Defendant's intentional concealment of such defects, its failure to warn consumers of such defects, its negligent misrepresentations, its failure to remove a product with such defects from the stream of commerce, and its negligent design of such products, Plaintiff used an unreasonably dangerous pressure cooker, which resulted in significant and painful bodily injuries upon the simple removal of the lid of the pressure cooker.

26. Consequently, Plaintiff seeks damages resulting from the use of Defendant's pressure cooker as described above, which has caused the Plaintiff to suffer from serious bodily injuries, medical expenses, physical pain, mental anguish, diminished enjoyment of life, wage loss and other damages.

CLAIMS FOR RELIEF

**COUNT I
STRICT LIABILITY**

27. Plaintiff incorporates by reference each preceding and succeeding paragraph as though set forth fully at length herein.

28. At the time of Plaintiff's injuries, Defendant's Pressure Cookers were defective and unreasonably dangerous for use by foreseeable consumers, including Plaintiff.

29. Defendant's Pressure Cookers were in the same or substantially similar condition as when they left the possession of Defendant.

30. Plaintiff did not misuse or materially alter their respective Pressure Cookers.

31. The Pressure Cookers did not perform as safely as an ordinary consumer would have expected them to perform when used in a reasonably foreseeable way.

32. Further, a reasonable person would conclude that the possibility and serious of harm outweighs the burden or cost of making the Pressure Cookers safe. Specifically:

- a. The Pressure Cookers designed, manufactured, sold, and supplied by Defendant were defectively designed and placed into the stream of commerce in a defective and unreasonably dangerous condition for consumers;
- b. The seriousness of the potential burn injuries resulting from the product drastically outweighs any benefit that could be derived from its normal, intended use;
- c. Defendant failed to properly market, design, manufacture, distribute, supply, and sell the Pressure Cookers, despite having extensive knowledge that the aforementioned injuries could and did occur;

- d. Defendant failed to warn and place adequate warnings and instructions on the Pressure Cookers;
- e. Defendant failed to adequately test the Pressure Cookers; and
- f. Defendant failed to market an economically feasible alternative design, despite the existence of the aforementioned economical, safer alternatives, that could have prevented the Plaintiff' injuries and damages.

33. Defendant's actions and omissions were the direct and proximate cause of the Plaintiff's injuries and damages.

WHEREFORE, Plaintiff demands judgment against Defendant for compensatory and punitive damages, together with interest, costs of suit, attorneys' fees, and all such other relief as the Court deems proper.

COUNT II
NEGLIGENCE

34. Plaintiff incorporates by reference each preceding and succeeding paragraph as though set forth fully at length herein.

35. Defendant has a duty of reasonable care to design, manufacture, market, and sell non-defective Pressure Cookers that are reasonably safe for their intended uses by consumers, such as Plaintiff and his family.

36. Defendant failed to exercise ordinary care in the manufacture, sale, warnings, quality assurance, quality control, distribution, advertising, promotion, sale and marketing of its Pressure Cookers in that Defendant knew or should have known that said Pressure Cookers created a high risk of unreasonable harm to the Plaintiff and consumers alike.

37. Defendant was negligent in the design, manufacture, advertising, warning, marketing and sale of its Pressure Cookers in that, among other things, it:

- a. Failed to use due care in designing and manufacturing the Pressure Cookers to avoid the aforementioned risks to individuals;

- b. Placed an unsafe product into the stream of commerce;
- c. Aggressively over-promoted and marketed its Pressure Cookers through television, social media, and other advertising outlets; and
- d. Were otherwise careless or negligent.

WHEREFORE, Plaintiff demands judgment against Defendant for compensatory and punitive damages, together with interest, costs of suit, attorneys' fees, and all such other relief as the Court deems proper.

COUNT III
NEGLIGENT DESIGN DEFECT

38. Plaintiff incorporates by reference each preceding and succeeding paragraph as though set forth fully at length herein.

39. Defendant is the manufacturer, seller, distributor, marketer, and supplier of the subject Pressure Cookers, which was negligently designed.

40. Defendant failed to exercise reasonable care in designing, developing, manufacturing, inspecting, testing, packaging, selling, distributing, labeling, marketing, and promoting its Pressure Cookers, which were defective and presented an unreasonable risk of harm to consumers, such as the Plaintiff.

41. As a result, the subject Pressure Cookers, including Plaintiff's Pressure Cooker, contain defects in their design which renders them unreasonably dangerous to consumers, such as the Plaintiff, when used as intended or as reasonably foreseeable to Defendant. The defect in the design allows consumers such as Plaintiff to open the lid while the unit remains pressurized, despite the appearance that all the pressure has been released from the unit, and causes an unreasonable increased risk of injury, including, but not limited to, first, second and third-degree scald burns.

42. Plaintiff in this case used his Pressure Cooker in a reasonably foreseeable manner and did so as substantially intended by Defendant.

43. The subject Pressure Cooker was not materially altered or modified after being manufactured by Defendant and before being used by Plaintiff.

44. The design defects allowing the lid to open while the unit was still pressurized directly rendered the Pressure Cookers defective and were the direct and proximate result of Defendant's negligence and failure to use reasonable care in designing, testing, manufacturing, and promoting the Pressure Cookers.

45. As a direct and proximate result of Defendant's negligent design of its Pressure Cookers, the Plaintiff in this case suffered injuries and damages described herein.

WHEREFORE, Plaintiff demands judgment against Defendant for compensatory and punitive damages, together with interest, costs of suit, attorneys' fees, and all such other relief as the Court deems proper.

COUNT IV
NEGLIGENT FAILURE TO WARN

46. Plaintiff incorporates by reference each preceding and succeeding paragraph as though set forth fully herein.

47. At the time in which the Pressure Cooker was purchased, up through the time Plaintiff was injured, Defendant knew or had reason to know that its Pressure Cookers were dangerous and created an unreasonable risk of harm to consumers.

48. Defendant had a duty to exercise reasonable care to warn consumers of the dangerous conditions or the facts that made its Pressure Cookers likely to be dangerous.

49. As a direct and proximate result of Defendant's negligent failure to warn of the dangers of its Pressure Cookers, the Plaintiff in this case suffered injuries and damages described herein.

WHEREFORE, Plaintiff demands judgment against Defendant for compensatory and punitive damages, together with interest, costs of suit, attorneys' fees, and all such other relief as

the Court deems proper.

COUNT V
BREACH OF IMPLIED WARRANTY OF FITNESS
FOR A PARTICULAR PURPOSE

50. Plaintiff incorporates by reference each preceding and succeeding paragraph as though set forth fully at length herein.

51. Defendant manufactured, supplied, and sold its Pressure Cookers with an implied warranty that they were fit for the particular purpose of cooking quickly, efficiently and safely.

52. Members of the consuming public, including consumers such as the Plaintiff, were the intended third-party beneficiaries of the warranty.

53. Defendant's Pressure Cookers were not fit for the particular purpose as a safe means of cooking, due to the unreasonable risks of bodily injury associated with their use.

54. The Plaintiff in this case reasonably relied on Defendant's representations that its Pressure Cookers were a quick, effective and safe means of cooking.

55. Defendant's breach of the implied warranty of fitness for a particular purpose was the direct and proximate cause of Plaintiff's injuries and damages.

WHEREFORE, Plaintiff demands judgment against Defendant for compensatory and punitive damages, together with interest, costs of suit, attorneys' fees, and all such other relief as the Court deems proper.

COUNT VI
BREACH OF IMPLIED WARRANTY OF MERCHANTABILITY

56. Plaintiff incorporates by reference each preceding and succeeding paragraph as though set forth fully at length herein.

57. At the time Defendant marketed, distributed and sold its Pressure Cookers to the Plaintiff in this case, Defendant warranted that its Pressure Cookers were merchantable and fit for the ordinary purposes for which they were intended.

58. Members of the consuming public, including consumers such as the Plaintiff, were intended third-party beneficiaries of the warranty.

59. Defendant's Pressure Cookers were not merchantable and fit for its ordinary purpose, because they had the propensity to lead to the serious personal injuries as described herein in this Complaint.

60. Plaintiff purchased his Pressure Cooker with the reasonable expectation that it was properly designed and manufactured, free from defects of any kind, and that they were safe for its intended, foreseeable use of cooking.

61. Defendant's breach of implied warranty of merchantability was the direct and proximate cause of Plaintiff's injury and damages.

WHEREFORE, Plaintiff demands judgment against Defendant for compensatory and punitive damages, together with interest, costs of suit, attorneys' fees, and all such other relief as the Court deems proper.

COUNT VII

PUNITIVE DAMAGES

62. Plaintiff incorporates by reference each of the allegations set forth in this Complaint as though fully set forth herein.

63. The acts, conduct, and omissions of Defendant, as alleged throughout this Complaint, were willful and malicious. It is unconscionable and outrageous that Defendant would risk the health, safety, and well-being of consumers, including the Plaintiff in this case. Despite its knowledge that the lid could be prematurely removed while the unit remained pressurized, Defendant made

conscious decisions not to redesign, despite the existence of an economically feasible, safer alternative design, and not to adequately label, warn or inform the unsuspecting consuming public about the dangers associated with the use of their pressure cookers. Defendants' outrageous conduct rises to the level that Plaintiff should be awarded punitive damages to deter Defendant from this type of outrageous conduct in the future, as well as to discourage other Defendants from placing profit above the safety of consumers in the United States of America.

64. Prior to and during the manufacturing, sale, and distribution of its pressure cookers, Defendant knew that said pressure cookers were in a defective condition as previously described herein and knew that those who purchased and used their pressure cookers, including Plaintiff, could experience severe physical, mental, and emotional injuries.

65. Further, Defendant knew that its pressure cookers presented a substantial and unreasonable risk of harm to the public, including Plaintiff, and as such, Defendant unreasonably subjected consumers of said pressure cookers to risk of serious and permanent injury from their use.

66. Despite its knowledge, Defendant, for the purpose of enhancing their profit, knowingly and deliberately failed to remedy the known defects in their pressure cookers, and failed to warn the public, including Plaintiff, of the extreme risk of injury occasioned by said defects inherent in them. Defendant intentionally proceeded with the manufacturing, sale, distribution and marketing of their pressure cookers knowing these actions would expose consumers, such as the Plaintiff, to serious danger in order to advance their pecuniary interest and monetary profit.

67. Defendants' conduct was despicable and so contemptible that it would be looked down upon and despised by ordinary decent people and was carried on by Defendants with willful and conscious disregard for the safety of the Plaintiff, his family, and consumers like them, entitling the Plaintiff to punitive damages.

DEMAND FOR JURY TRIAL

Plaintiff demands that all issues of fact of this case be tried to a properly impaneled jury to the extent permitted under the law.

PRAYER FOR RELIEF

WHEREFORE, Plaintiff demands judgment against the Defendant for damages, to which he is entitled by law, as well as all costs of this action, interest and attorneys' fees, to the full extent of the law, whether arising under the common law and/or statutory law, including:

- a. judgment for Plaintiff and against Defendant;
- b. damages to compensate Plaintiff for his injuries, economic losses and pain and suffering sustained as a result of the use of the Defendant's Pressure cookers;
- c. pre and post judgment interest at the lawful rate;
- d. a trial by jury on all issues of the case;
- e. an award of attorneys' fees; and
- f. for any other relief as this Court may deem equitable and just, or that may be available under the law of another forum to the extent the law of another forum is applied, including but not limited to all reliefs prayed for in this Complaint and in the foregoing Prayer for Relief.

Date: February 19, 2024

Respectfully submitted,

**MILBERG COLEMAN BRYSON PHILLIPS
GROSSMAN, LLC**

/s/ Randi Kassan, Esq.

Randi Kassan, Esq.

100 Garden City Plaza, Suite 500

Garden City, NY 11530

516-741-5600 / 516-741-0128 (fax)

Rkassan@milberg.com

In association with:

JOHNSON BECKER, PLLC

Michael J. Johnson, Esq.

Pro Hac Vice to be filed

Adam J. Kress, Esq.

Pro Hac Vice to be filed

Anna Rick, Esq.

Pro Hac Vice to be filed

444 Cedar Street, Suite 1800

St. Paul, MN 55101

(612) 436-1800 /612-436-1801 (fax)

mjohnson@johnsonbecker.com

akress@johnsonbecker.com

arick@johnsonbecker.com

Attorneys for Plaintiff

EXHIBIT A

Bella Multicooker Model Number
M-80B23G Owner's Manual



6 LITRE PRESSURE COOKER



N
tc
If
uj

Instruction Manual
Recipe Guide

Table of Contents

Product Safety	2-3
Electrical Safety	3-4
Features	5-6
Introduction to Pressure Cooking	7
Before First Use	7
Using Your Pressure Cooker	7-8
The Delay Function.....	9
Warm/Cancel Functions.....	9
To Remove the Lid.....	9
One Touch Digital Functions.....	10-11
Cooking Times	12-13
Hints and Tips for Pressure Cooking	13-14
Care and Cleaning	14
Storing Instructions.....	14
Servicing.....	14
Guarantee	15
Recipes.....	16-25

INTRODUCTION**Thank you for purchasing this product.**

You may already be familiar with using a similar product, but do please take the time to read these instructions – they have been written to ensure you get the very best from your purchase.

Safety is Important

To ensure your safety and the safety of others, please ensure you read the Product Safety and Electrical Safety information before you operate this product. Please pay particular attention to any warnings and cautions contained within these instructions. Keep these instructions in a safe place for future reference.

What can you expect from the Bella Pressure Cooker?

This fantastic unit is one pot cooking and it saves time by cooking up to 70% faster than conventional cooking. At the touch of a button you can create delicious meals in a fraction of the time than on the stove top or in a slow cooker. The pre-programmed settings mean that you simply select a function and away you go, you don't have to worry about pressure levels as the unit does it all for you. Instead of using lots of pots and pans, all the preparation is carried out in one pot, you can brown meat and caramalise vegetables, it's not only easier but saves on washing up!

Due to our policy of continuous improvement, the actual product may differ slightly from the one illustrated in this booklet.

PRODUCT SAFETY

Read this manual thoroughly before first use, even if you are familiar with this type of product. The safety precautions enclosed herein reduce the risk of fire, electric shock and injury when correctly adhered to. Keep the manual in a safe place for future reference. If applicable, pass these instructions on to the next owner of the appliance.

Always follow basic safety precautions and accident prevention measures when using an electrical appliance, including the following:

**WARNING: TO REDUCE THE RISK OF FIRE, ELECTRICAL SHOCK, OR INJURY:
READ ALL INSTRUCTIONS CAREFULLY BEFORE USING YOUR APPLIANCE.**

1. Ensure the unit is used on a stable, level and heat-resistant surface out of the reach of children. If necessary place a chopping board or heat resistant mat underneath the Pressure Cooker during use.
2. Always attach the connector end of the power cord into the appliance before inserting the plug into the wall socket.
3. Do not touch the hot surfaces of the Pressure Cooker, use the handles only. Use oven gloves or a cloth when opening the lid or handling the inner cooking pot as steam will escape.
4. This appliance can be used by children aged from 8 years and above and persons with reduced physical, sensory or mental capabilities or lack of experience or knowledge if they have been given supervision or instruction concerning use of the appliance in a safe way and understand the hazards involved. Children shall not play with the appliance. Cleaning and user maintenance shall not be made by children without supervision.
5. Do not operate the appliance with a damaged cord or plug, or after the appliance malfunctions or has been damaged in any manner. Take it to a qualified service technician for investigation.
6. Do not let the cord hang over the edge of the table or counter.
7. Do not use this Pressure Cooker on or near a hot plate. Do not position it under hanging kitchen cabinets as steam from the pressure release may cause damage.
8. Always check the silicone sealing ring is correctly positioned before use.
9. Before placing the removable cooking pot into the unit, ensure the pot base and the internal heating plate are clean and free of any food debris.
10. Do not place food or liquid directly into the base of the unit. Only the removable cooking pot is designed to contain food or liquid.
11. Never obstruct the pressure release valve.
12. Always check the pressure release valve to ensure it is not clogged before use.
13. **NEVER ATTEMPT TO OPEN THE LID WHEN THE UNIT IS UNDER PRESSURE.**
Do not open the unit until the pressure has been released. If the lid is difficult to rotate do not force it as the unit is still under pressure and it can be hazardous if forced. See the instructions on how to remove the lid on page 9.
14. Never operate the Pressure Cooker without food or liquid in the removable cooking pot. Do not fill the pot over 4/5 full. When cooking foods that expand or foam such as dried vegetables, legumes, beans and grains do not fill the pot over 1/2 full. If overfilling occurs it may block the pressure release valve and cause a build-up of pressure.
15. This Pressure Cooker cooks under pressure, improper use may result in scalding. Follow the "Using your Pressure Cooker" instructions on page 8 and make sure the lid is closed properly before operating.
16. Be aware that certain foods can foam, froth and splutter which can block the pressure release valve, these foods include apple sauce, cranberries, pearl barley,

oatmeal and other cereals, noodles, pasta and rhubarb. Extra care should be taken when cooking anything containing these.

17. Do not touch the pressure release valve when in use. Only turn to release the pressure after the unit has finished cooking.
18. Ensure there is sufficient water in the removable cooking pot when steaming; it should reach the minimum 1/5 mark at least.
19. Do not use the Pressure Cooker for Deep Frying.
20. Do not use metal utensils as they will scratch the premium non-stick coating on the removable cooking pot. Use heat resistant plastic utensils or use a wooden spoon.
21. Do not move the appliance when in use.
22. Always keep your hands and face away from the pressure release valve, when releasing the pressure.
23. Use extreme caution when removing the lid after cooking. Always tilt the lid away from you, so that any steam does not come into contact with your face.
24. To protect against electric shock, do not immerse the Pressure Cooker, base unit, power cord or plug into water or any other liquid.
25. Unplug from the mains socket using dry hands when not in use and before cleaning. Allow to cool before putting on or taking off parts.

Do not use the appliance for other than its intended use, this is for HOUSEHOLD USE ONLY.

ELECTRICAL SAFETY

WARNINGS!

- Read these instructions thoroughly before using this appliance or connecting it to the mains supply.
- A 13 amp BS1362 ASTA approved fuse must be fitted.
- This appliance must be earthed.
- There are no user-serviceable parts inside this appliance.
- Always refer servicing to qualified service personnel.
- The mains lead of this product is not replaceable by the user. If the mains lead is damaged, do not use until the appliance has been inspected and approved by a qualified electrician.
- Do not allow this product to be exposed to rain or moisture during use or storage.

Before switching on, make sure that the voltage of your electricity supply is the same as that indicated on the product rating plate. Connecting it to any other power source may cause damage.

This product may be fitted with a non-rewireable plug. If it is necessary to change the fuse in the plug, the fuse cover must be refitted. If the fuse cover becomes lost or damaged, the plug must not be used until a suitable replacement is obtained. If the plug has to be changed because it is not suitable for your socket, or due to damage, it should be cut off and a replacement fitted, following the wiring instructions shown. The old plug must be disposed of safely because inserting it into a 13 amp socket could cause an electrical hazard.

ELECTRICAL SAFETY

The wires in the power cable of this product are coloured in accordance with the following code:

Blue = Neutral, Brown = Live, Green/Yellow = Earth

If the markings on the terminals of your plug do not correspond to the colours of the wires in the power cable, proceed as follows:

- The wire which is coloured **Blue** must be connected to the terminal which is marked **N** or coloured **Black**.
- The wire which is coloured **Brown** must be connected to the terminal which is marked **L** or coloured **Red**.
- The wire which is coloured **Green/Yellow** must be connected to the terminal which is marked with the earth symbol (\perp) or coloured **Green**.

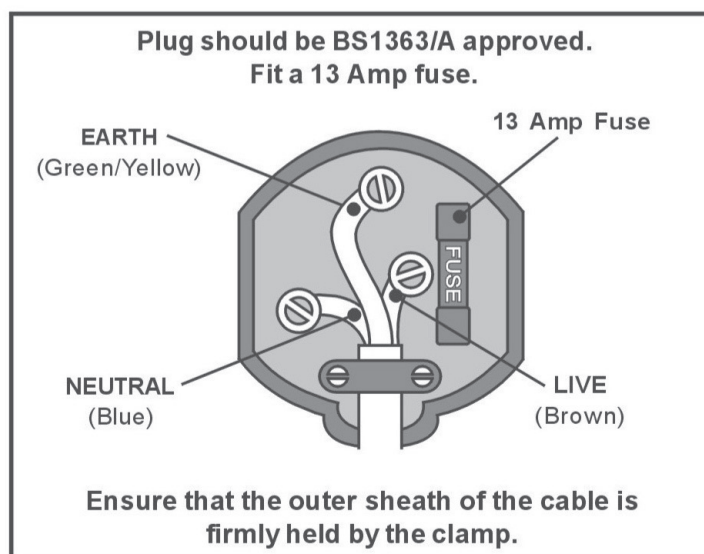

Features

Figure 1

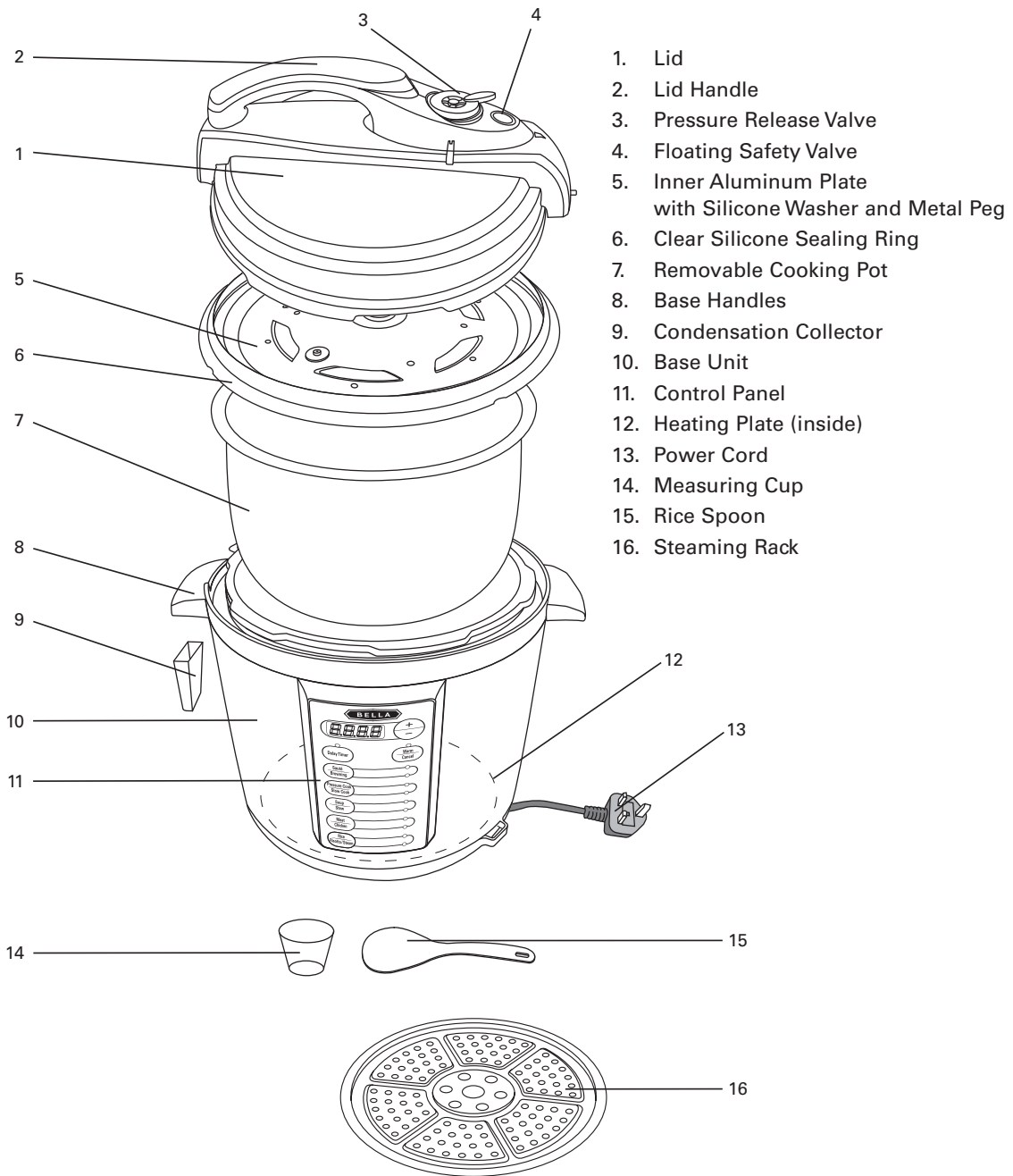
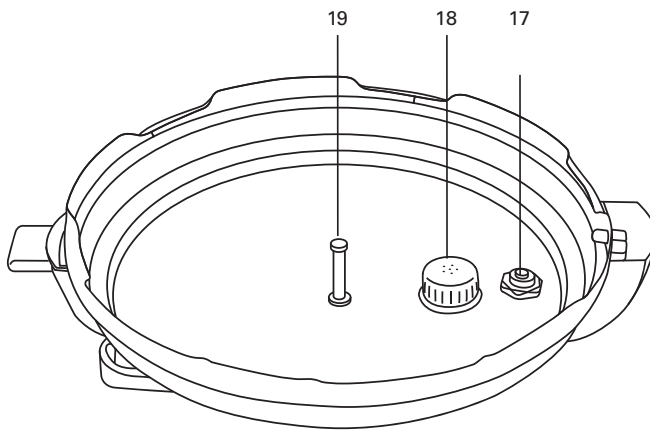
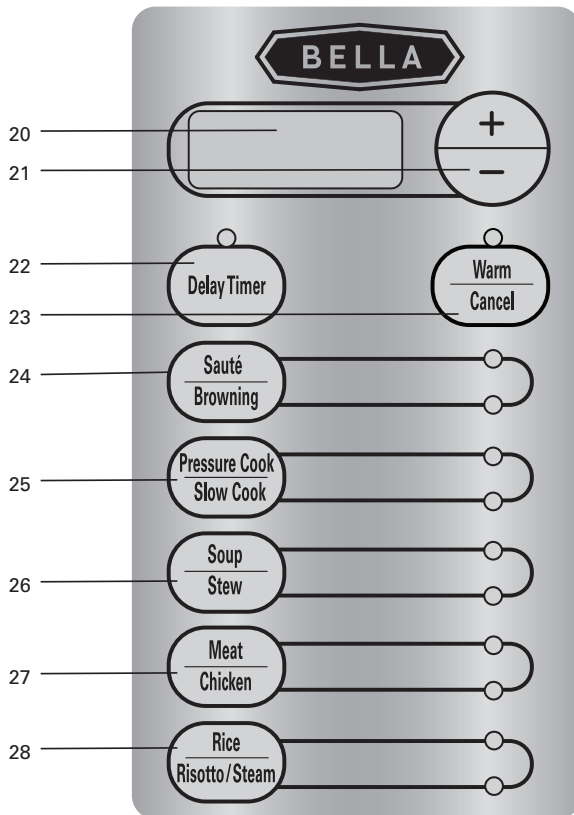

Figure 1 (cont'd)



Underside of the lid

- 17. Floating Valve with Sealing Ring
- 18. Pressure Release Valve Cover
- 19. Centre Post



Control Panel

- 20. LED Display
- 21. Increase/Decrease time button
- 22. Delay Timer
- 23. Warm/Cancel
- 24. Sauté/Browning
- 25. Pressure Cook/Slow Cook
- 26. Soup/Stew
- 27. Meat/Chicken
- 28. Rice/Risotto/Steam

Introduction to Pressure Cooking

Discover the secrets of pressure cooking with this wonderful pressure cooker that will help you cook faster, healthier and tastier meals with unbelievable speed and ease. This pressure cooker offers 11 cooking settings with the touch of a button. Slow cook all day long or whip up a quick delicious meal, this pressure cooker is the perfect sous-chef. No more tough cuts of meat that take hours to cook, only delicious succulent meat with the nutrients and flavours locked in.

Before First Use

1. Remove all labels and tags from the product. Carefully unpack your pressure cooker; remove all packaging materials from the parts and accessories.
2. Remove the lid by turning the handle clockwise to the UNLOCK position and lifting the lid off the unit.
3. Wash the cooking pot and all accessories that will come into contact with food in hot soapy water with a sponge or dishcloth. DO NOT use a scouring pad or any abrasive materials as this could damage the product. Rinse the cooking pot, accessories and lid thoroughly and dry.
4. Avoid leaving the lid fully immersed in water as it will take a long time to drain and dry.
5. Attach the condensation collector by sliding it into place (see Figure 2).

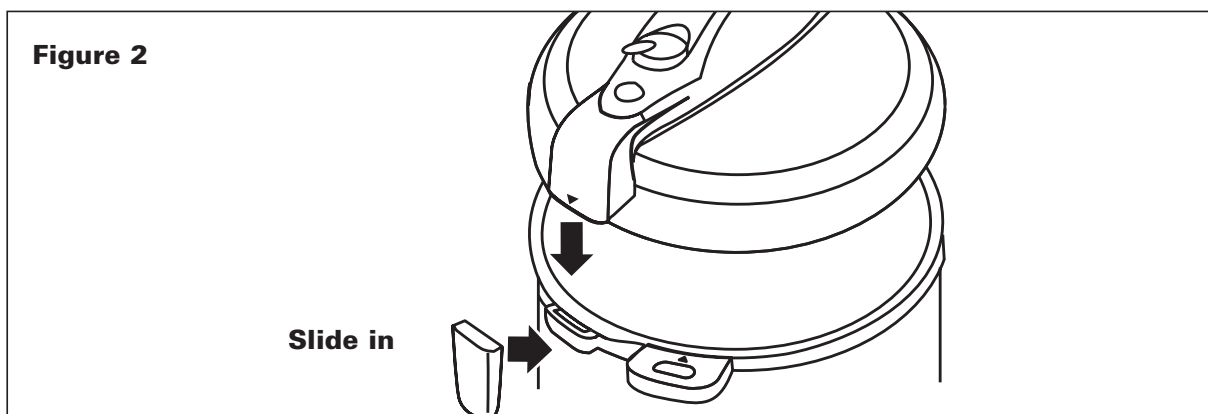

6. Ensure that the well dried cooking pot is sitting flat in the base unit with proper contact.
7. Never lift the pressure cooker using the lid handle, always use base handles.

NOTE: DO NOT IMMERSE THE MAIN COOKING UNIT IN WATER!

Using Your Pressure Cooker

Cooking under pressure raises the temperature of the liquid and steam inside to well above boiling point and results in food being cooked up to 70% faster. This method of cooking retains more vitamins and minerals and enhances natural flavours. It also means that less energy is used because cook times are so quick saving you both time and money.

NOTE: Place the base on a dry, level, heat resistant surface, away from the edge of the work surface.

Do not use the appliance on the floor or under hanging wall cabinets. Small amounts of steam will escape from the pressure release valve while heating and sometimes during the cooking cycle. This is perfectly normal.

1. Place the dry and clean cooking pot into the base unit and ensure that it is seated properly on the heating plate.
2. Check that silicone sealing ring is securely placed around the aluminum plate and the aluminum plate is attached to the housing lid with the metal peg facing **outwards**. If the plate is not correctly fitted the lid will not close properly and the unit will not be able to build up pressure, so ensure it all assembles correctly (see Figure 3).

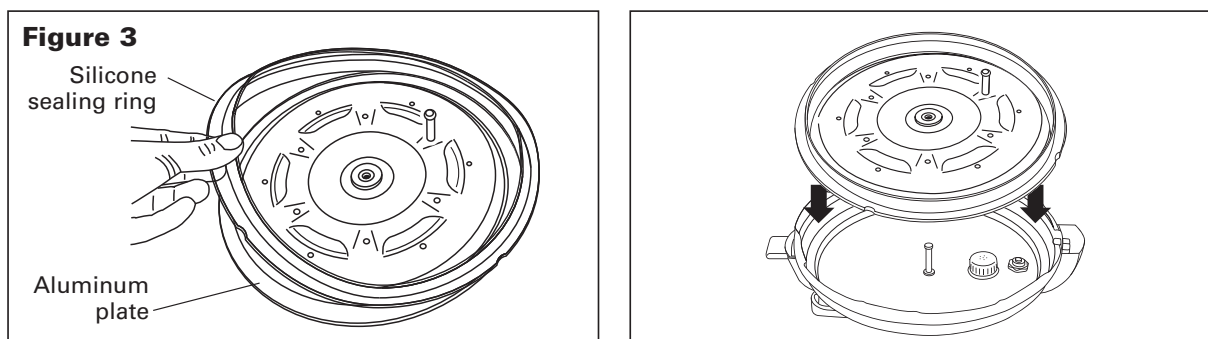

3. If you are sautéing or browning food first before cooking, add some oil or butter to the cooking pot and select either option make sure you do this with the lid OFF. When you have finished browning press the cancel option.
4. Place the remaining ingredients to be cooked in the cooking pot and add liquid according to your recipe. Make sure that amount of food and liquid combined reaches the minimum mark on the inside of the cooking pot, but never more than the 4/5 mark on the cooking pot as the food needs space to boil and bubble (see fig. 4). When cooking food that expands such as rice, dried beans, grains and legumes, do not fill more than the 3/5 mark on the cooking pot.
5. Secure the lid to the appliance. Place the lid on the appliance in the "UNLOCK" position, then turn the lid anti-clockwise to the "LOCK" position (see Figure 5). Ensure that the lid fits tightly, you will hear a click once correctly in place.
6. Once the lid is closed securely, attach the power cord to the base of the unit then plug the cord into power socket. Use the CONTROL PANEL to choose the appropriate food type and adjust the default cooking time using the +/- button to suit the recipe that you are cooking.
7. Set the pressure release valve to the PRESSURE setting as shown (see figure 6).
8. The pressure cooker will take a few minutes to build up pressure, during this time the LED panel will circle round. Once the required pressure is reached the time will become fixed and begin to countdown. The unit is now cooking under pressure. The LED panel may circle around during the cooking time, do not be alarmed the unit is simply maintaining pressure.
9. During initial use, you may notice a slight odour due to the burning off of manufacturing residue. This is completely normal, it does not affect the food being cooked and will disappear after a few uses.

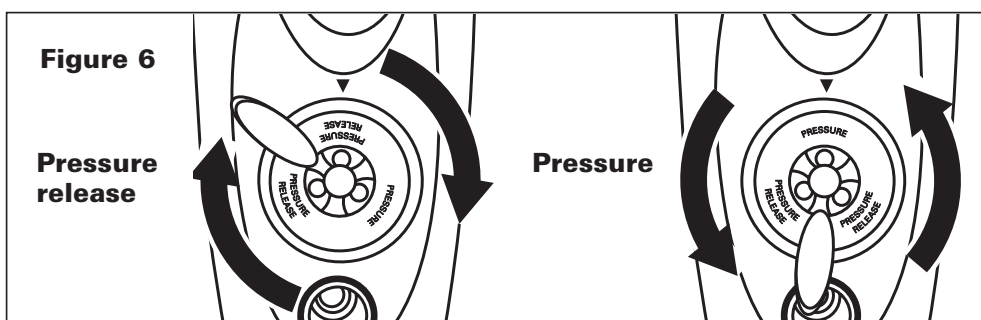
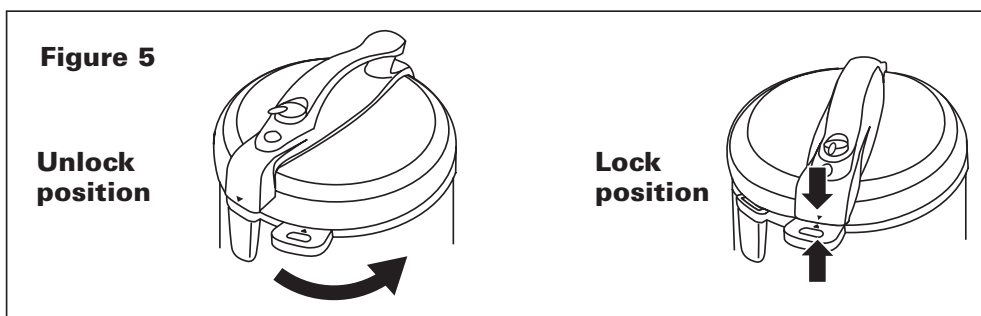
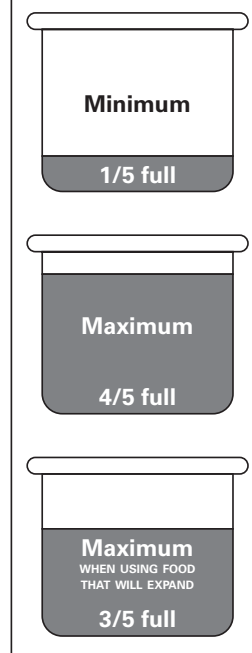
Figure 4**Figure 5****Unlock position****Lock position****Figure 6****Pressure release****Pressure**

The Delay Function

- Before selecting the cooking function press the DELAY TIMER button to delay the start of the cooking time. The delay timer can be adjusted up to a maximum delay time of 2 hours. Continue to press the button until the desired time delay is reached. The amount of time until the unit begins cooking will be displayed on the screen.
- Once the delay time has been selected use the CONTROL PANEL to choose the desired cooking setting (i.e. rice, soup, chicken etc) and adjust the cooking time using the +/- button. It will flash then automatically switch to the delay time. The delay time will start to count down and cooking will begin once the delay time has elapsed.

N.B Do not leave perishable foods such as meat, poultry, fish, cheese and dairy products at room temperature for longer than 2 hours.

- Please note that once the cooking time has counted down, the time may not be adjusted. If more or less cooking time is required. The cooking process must be cancelled and the timing must be reset to the required/desired time.
- During set up and while cooking, the WARM/CANCEL button can be pressed to cancel cooking at any time.

Warm/Cancel Functions

Once the cooking process is complete, the Pressure Cooker will beep and move automatically to the WARM function this is shown by a "bb" on the LED display. This function is used to keep cooked food warm up to 24 hours, however for maximum flavour the recommended hold time for food is no longer than 6 hours. This function is also to stop or cancel the current function.

NOTE: It is not recommended to use the WARM function for extended periods when cooking fish or chicken dishes.

To Remove the Lid

When the pressure cooking cycle has finished, the unit automatically switches to WARM. At this point you may choose to release the pressure in two ways. The floating pressure safety valve will not go down until pressure is released and you will not be able to open the lid.

1. **Natural Pressure Release** – This is recommended for anything with large amounts of liquid e.g. soups and stocks it will prevent the liquid inside from boiling over and blocking the pressure release valve. Following pressure cooking, allow the unit to remain on the WARM function. The pressure will begin to drop inside this can take from 12 minutes to 30 minutes depending on the amount of liquid inside. The lid can only be removed with the pressure has gone down.
2. **Quick Pressure Release** - Following pressure cooking, the cooker will beep, this indicates that the cooking time has finished. Press the Cancel Button to stop the WARM function and turn the Pressure Release Valve to the "Pressure Release" position using an oven mitt (see Fig 6). Hot Steam will be released. DO NOT put your hands or face near the unit when turning the valve. The lid will only open once all the pressure has been released. Turn the lid clockwise and unlock. When removing the lid, tilt the lid away from you, this way the steam is directed away from you to avoid being scalded by the escaping steam. Use oven mitts when removing the inner cooking pot. Only use non-stick utensils to serve from the cooking pot as any hard utensils made from stainless steel or similar materials could damage the non-stick surface of the inner cooking pot.

One Touch Digital Functions

For your convenience the pressure cooker has 11 pre-set options with default cook times. Based on your recipe you can choose any one of these settings Sauté, Browning, Pressure Cook, Slow Cook, Soup, Stew, Meat, Chicken, Rice, Risotto/Steam and Warm. Every button has 2 settings and a corresponding pair of lights next to it. To select a setting simply press the button and the corresponding light will indicate the selected setting (see Figure 7). You can adjust the cook time by pressing the + or – buttons. When the time has been selected the LED will flash until the unit builds up pressure. When the pressure is at the correct level inside the cooking time will start to countdown.



Sauté

This is great for caramelizing vegetables which adds more flavour to your dishes, simply place a little oil or butter in the base of the cooking pot and add your onions, carrots etc. Cooking will soften them and add a delicious flavour, you can also warm spices to release their flavour. This setting is also perfect to reduce and thicken any remaining liquid at the end of cooking time as there is no evaporation during pressure cooking so you need to add less liquid. Sometimes excess liquid may need thickening you can either add a cornflour and water mixture or simply bubble it for 10 minutes to reduce the liquid.

Browning

As meat will not brown during the pressure cooking process it is recommended to brown meat before so that this not only tastes better but the finished dish will look better. By browning meat, such as lamb, it will reduce the amount of fat present in the final meal and will also add a richer flavour. Use this setting for browning meat, chicken or game. Ensure you cut them into even sized pieces so they cook evenly. Add oil or butter to the base of the pot and sear the meat. If you have a lot of meat you may have to brown in batches this will maintain a high heat and ensure the meat is browned rather than stewed.

Pressure Cook

This setting is for general pressure cooking. Anything can be cooked on this setting that isn't included in one of the one touch digital options. Just adjust the time according to your recipe.

Slow Cook

This is for long slow cooking up to 12 hours. It is NOT cooked under pressure. This is ideal if you need to be out the house all day and want to eat as soon as you come home. Use this setting as you would a slow cooker, so any recipes suitable for a slow cooker would be good for this setting. Remember this is low and slow, so cheap cuts of meat are better. Save your premium cuts for super fast cooking using a pressure setting.

Soup

Ideal for soups and stocks, just ensure that you do not overfill the cooking pot and make sure you use the NATURAL PRESSURE RELEASE when removing the lid for safety following the instructions detailed on page 9.

Stew

This is great for Meat Ragu, Chilli Con Carne, Casseroles and even pie fillings like Steak and Ale.

Meat

This is great for larger pieces of meat, such as lamb shanks, pork shoulder, ribs, brisket, gammon etc. Brown them first using the browning option then simply select this setting and adjust your time to suit your recipe.

Chicken

This setting is great for cooking a whole chicken for a delicious pot roast, then pop it under a pre-heated grill to crisp up the skin if you prefer it golden. You can also cook chicken legs, thighs, drumsticks and fillets.

Rice

Cook perfect fluffy rice on this setting. You can add spices or herbs during cooking and add salt if required. Also a drizzle of oil helps to reduce the foam (see Hints and Tips for cooking guidelines).

Risotto/Steam

Make delicious creamy risotto on this setting in a fraction of the time without the need to keep stirring. Simply sauté the grains of rice in some butter or oil until they turn opaque then add the liquid.

To steam simply add sufficient water to the cooking pot to come to the 1/5 level on measuring scale inside the cooking pot. Place the steam rack into the pot, it will fit inside the pot on the ridge above the water (see Fig. 8). Add the food to be steamed on top of the rack cutting vegetables into even pieces and place the lid on top of the unit and turn the pressure release valve to the pressure setting. Select the steam function and adjust the time accordingly. If you wish to steam larger items such as puddings, you will need to place a trivet in the bottom of the cooker for the pudding bowl to sit on.

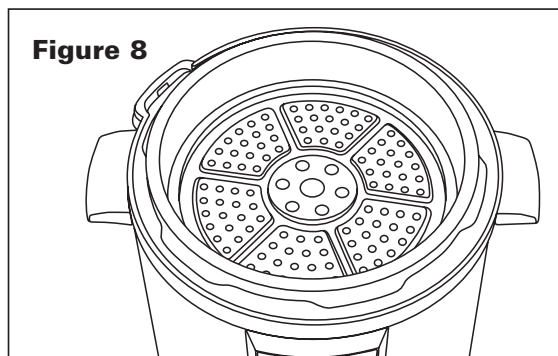
**Warm**

The unit automatically switches to keep warm as soon as the cooking has finished. This is great if not everybody is eating at the same time. This can be cancelled at any point by pressing the button again to cancel the function. This setting can also be used to keep food warm that has NOT been cooked in the pressure cooker. It can be used as a food warmer to keep already cooked food hot. This is especially good if you are having a party and need to keep a big pot of Chilli Con Carne hot for your guests. Using this function it is not recommended to keep food warm for more than 6 hours as this will affect the taste and texture of the food.

Function	Default Cooking Time
Sauté	Stay ON (30 min.)
Browning	Stay ON (30 min.)
Pressure Cook	30 min (Max 99 min.)
Slow Cook	4 h (Max 12 hrs.)
Soup	20 min.
Stew	30 min.
Meat	60 min.
Chicken	45 min.
Rice	10 min.
Risotto/Steam	25 min.
Warm	Stay ON

Cooking Times

Cooking Rice

White rice (Basmati, Long Grain) takes 3 minutes to cook and uses the fully absorption method. The rice will be slightly stickier than rice cooked on the stove top. Use the marking on the pot as a guide i.e 2, 4, 6 cups. Fill the water in the pot FIRST to the level required and then add the corresponding cup of rice.

Level on cooking pot	Cups of rice	Oil tbsp. quantity	Yield (cups) when cooked
2	2	1	6
4	4	1	12
6	6	2	18
8	8	2	24

Set the time to 3 minutes and use the NATURAL PRESSURE RELEASE METHOD. During this time the rice will absorb the steam and will be dry not wet. Cooking wholegrain/brown rice is very different. It needs to be cooked in lots of water and then drained. Only cook a maximum of 2 CUPS grain/brown rice in 6.5 cups of water.

Rice type	Cooking time
Aborio/ Paella	Sauté rice in butter/oil until opaque. Add liquid. Cook for 6-8 minutes. Use the Quick Release.
Brown Rice	Cook under pressure for 10 minutes. Use Natural Pressure Release for at least 10 minutes then quick release.
Wild Rice	Cook under pressure for 20 minutes. Use Natural Pressure Release for at least 10 minutes then quick release.

Cooking Vegetables

When steaming vegetables, chop them up into even size pieces so they cook evenly. Remember most vegetables take a few minutes to cook. Add boiling water to the pot this will bring the unit up to pressure much quicker. Always use the quick steam release to avoid overcooking.

Vegetables Cooking Times

Artichokes 4 medium/large	7 to 9 minutes
Asparagus whole	1 minutes
Beans, Green cut into 2-inch lengths	1 to 2 minutes
Beans, runner cut into 1- inch slices	2 minutes
Beetroot , medium-large	24 to 26 minutes
Broccoli, cut into large florets	2 to 3 minutes
Cauliflower, cut into large florets	2 to 3 minutes
Carrots, cut into 2-inch lengths	8 minutes
Carrots, ½-inch slices	2 to 3 minutes
Corn on the cob, 2 ears	4 minutes
Courgette, cut into ½-inch slices	1 to 3 minutes
Greens, cabbage, kale, cut into 1-inch strips	1-2 minutes
Onions, baby peeled	2 to 4 minutes
Parsnips, peeled, cut into 2-inch pieces	3 to 4 minutes
Parsnips, ½-inch slices	1 to 2 minutes
Potatoes White, medium quartered	5 to 7 minutes
Potatoes Sweet, 2-inch cubes	5 to 6 minutes
Squash Butternut, peeled & sliced	3 to 4 minutes

Cooking Meat and Poultry

Food	Cooking Time (in minutes)
Chicken	
Whole 1.5kg	25-30
Breast fillets	6-8
Thigh and leg bone in	15
Thigh boneless	10
Beef	
Brisket	55
Oxtail	40-45
Shin	40-50
Stewing	15
Steak Mince	10-15
Lamb	
Leg	35-40
Shanks	60
Shoulder, cubed	25
Stewing, cubed	15
Pork	
Chops	10 (brown first)
Shoulder	60-70
Leg, cubed	30

Hints and Tips for Pressure Cooking

- It really is worth sautéing vegetables, browning meat and warming spices before pressure cooking. It may take a little longer to prepare but the end result will be worth it. It adds depth of flavour to the finished result.
- The amount of liquid required when pressure cooking is much less than traditional methods as there is no evaporation during cooking. Any excess liquid at the end of cooking can be thickened or reduced using the Sauté function or simply use a cornflour/water mixture to thicken any remaining liquid.
- Hot liquid/food will come to pressure quicker than cold liquid/food.
- Pressure cooking allows less tender cuts of meat to be cooked quickly and achieve a tender juicy result.

Beef	Lamb	Pork	Chicken
Shin, Chuck and Blade (Braising Steak) Brisket, Silverside and Oxtail.	Shanks, Shoulder, Breast, Scrag and Middle neck.	Diced leg, Shoulder, Spare ribs and Belly.	Drumsticks, Thighs on the bone or Fillets and Legs.

- When preparing vegetables they should be cut into even-sized pieces to ensure even cooking.
- Vegetables can be cooked from frozen very easily, they may take slightly longer than if they were thawed, just make sure they are piping hot before eating.
- It is not recommended to cook meat, fish, poultry or game from frozen. It is recommended to thaw it first as thawed food can either be marinated or browned first which will add heaps of flavour. Also frozen meat will release the fat into the cooking liquid which will result in a fatty sauce. Thawed meat that is browned first will release fat which can be poured away before cooking. If meat, fish, poultry or game is cooked from frozen the cooking time will be longer and the use of a thermometer is essential to ensure that the internal temperature of the product has reached AT LEAST 75°C, if it is not, continue to cook until it is reached.
- When pot roasting meat, add sliced vegetables on the base of the pot such as thickly sliced onions, carrots or celery. Sit the meat on top of these and the flavours from the vegetables will enrich any sauce or gravy. Simply strain the liquid through a sieve and thicken and serve with your pot roast.

- When cooking dried beans and peas, soak them for a minimum of 3 hours in boiling water first or overnight, this will ensure that they remain intact and do not split. Or you can use the quick soak method which is to pre-cook them in the pressure cooker before adding to your recipe for further cooking. Simply rinse and pick out any broken or discolored beans, for every 1 cup of beans add 4 cups of water and a teaspoon of salt to the cooking pot, this prevents the beans from splitting. Add a good drizzle of oil and cook for 4 minutes under pressure. Release the pressure carefully as beans foam. Drain and rinse lightly then use in your recipe that calls for pre-soaked beans. Remember do not fill more than half full as beans foam.
- To adapt your own recipes, the general rule is that cooking time will be at least 1/3 to 1/2 of the traditional cooking time. Reduce your cooking liquid by at least half – it may be trial and error at first with your recipe to get it right. You may wish to add vegetables and canned pulses at the end of cooking to avoid overcooking.

Care and Cleaning

1. Unplug and let the unit cool down before cleaning.
2. Clean the base unit with a soft damp cloth. **DO NOT IMMERSE THE BASE INTO WATER OR ANY OTHER LIQUID.**
3. Wash the removable cooking pot in hot soapy water, using a sponge or washing up brush. Rinse and dry thoroughly.
4. Wipe the heating plate with a soft damp cloth and dry thoroughly.
5. Remove the condensation collector from the side of the unit, empty and wash thoroughly and let it dry, and replace it back into the original position on the Pressure Cooker.
6. Remove the sealing ring assembly from inside the lid by pulling on the metal peg. Carefully remove the clear silicone sealing ring from the inner aluminum plate and wash and dry thoroughly.
7. Remove the Pressure Release Valve by pulling it up and off and rinse with warm water and dry, replace it into position (see fig. 9).
8. Rinse the upper and underside of the lid with warm water and remove the Pressure Release Valve Cover by twisting and pulling off. Dry thoroughly and replace the Pressure Release Valve Cover by clipping it back into place (see fig. 10).
9. Replace the sealing ring assembly onto the lid making sure the **MAKE SURE THE METAL PEG ON THE INNER STEEL PLATE FACES OUT.** Push this onto the centre post on the lid (see Fig. 3).
10. Replace the cooking pot back into the unit. Store the unit with the lid loosely on top of the pressure cooker to prevent aromas, moulds and odours.

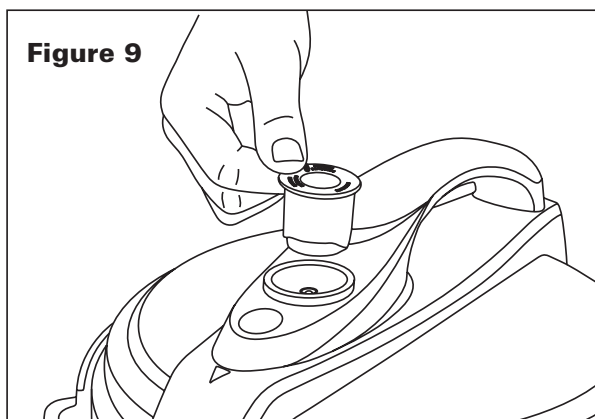

Figure 9

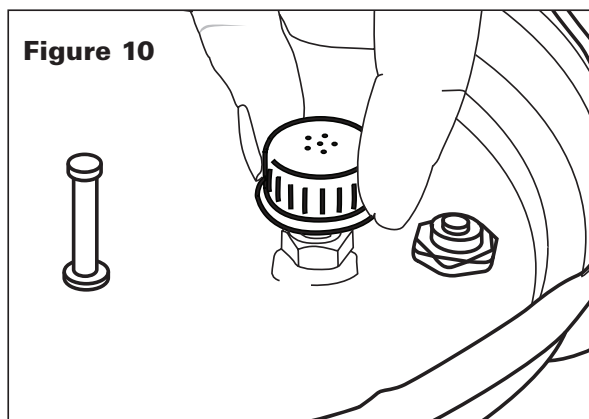

Figure 10

Storing instructions

1. Be sure all parts are clean and dry before storing.
2. Store the pressure cooker with cooking pot inside the base unit; and the lid locked. Store assembled unit in a clean dry place.
3. Never store the pressure cooker while it is hot or wet.
4. Never wrap cord tightly around the appliance; keep it loosely coiled.

Servicing

This appliance requires little maintenance. It contains no user serviceable parts. Do not try to repair it yourself. Any servicing requiring disassembly other than cleaning, must be performed by a qualified electrician.

GUARANTEE

This product is guaranteed for twelve months from the date of original purchase. Any defect that arises due to faulty materials or workmanship will either be replaced or refunded where possible during this period by the dealer from whom you purchased the unit.

The following conditions apply:

- The guarantee does not cover accidental damage, misuse, cabinet parts, knobs or consumable items.
- The product must be correctly installed and operated in accordance with the instructions contained in this manual.
- It must be used only for domestic purposes.
- The guarantee will be rendered invalid if the product is re-sold or has been damaged by inexperienced repair.
- Specifications are subject to change without notice.
- The manufacturer disclaims any liability for the incidental or consequential damages.
- The guarantee is in addition to, and does not diminish your statutory or legal rights.
- Valid in the UK only.

Customer Helpline: 0345 467 6743

DISPOSAL INFORMATION



Waste electrical products should not be disposed of with household waste. Please recycle where facilities exist. Check with your local authority for recycling advice.



For technical queries, please contact:

MPL Home Ltd, IMEX, 575 - 599 Maxted Road, Hemel Hempstead, Herts, HP2 7DX



Recipes

Risotto with Butternut Squash, Sage and Chestnuts

Serves 4-6

Ingredients

- 60g butter
- 20 cooked chestnuts, chopped
- 16 sage leaves, shredded
- 1 onion
- 500g risotto rice
- 450g butternut squash, chopped
- 1400ml vegetable stock
- 50g Parmesan cheese

Method

1. Add the butter to the cooking pot and select SAUTÉ, add all the chopped chestnuts and half the shredded sage, cook until the butter starts to brown slightly. Remove these with a slotted spoon and set aside for now.
2. Add the onion to the cooking pot and sauté until softened; add the rice, butternut squash and the remaining sage. Cook for a minute until the grains of rice start to turn opaque and then add the stock. Cancel the Sauté setting.
3. Lock the lid into place and select the RISOTTO setting and set the timer for 8 minutes and cook under pressure.
4. When the cooking time has finished, leave to rest for 5 minute before releasing the pressure.
5. Add most of the reserved cooked chopped chestnuts keeping a few back to garnish, and add a handful of grated parmesan cheese.
6. Serve each portion with a few of the reserved chestnuts on top and a sprinkle of parmesan cheese.

Moroccan Lamb Shanks with Chickpeas

Serves 4-6

Ingredients

- 4 lamb shanks
- 2 tbsp. Harissa paste
- Salt and pepper
- 1-2 tbsp. oil
- 1 onion chopped
- 1 cinnamon stick
- 2 tsp. ground ginger
- 2 tsp. ground cumin
- 1/2 tsp. ground allspice
- 1/4 tsp. ground mixed spice
- 1 x 400g can chopped tomatoes
- 200ml chicken stock
- 1 tbsp. honey, plus a little extra
- Half a lemon
- 1 x 400g can chickpeas, drained

Serve with cous cous

Method

1. Rub the harissa paste into the lamb shanks and season them with salt and pepper.
2. Select the BROWNING option and heat the oil in the cooking pot, brown two lamb shanks at a time on all sides remove when brown all over and set aside and repeat with the other two. Remove these and keep them to the side for minute.
3. Select SAUTÉ and add the onion to the cooking pot and cook until softened, add the spices and warm until fragrant. Add the tomatoes, stock and honey and add the lamb shanks back to the cooking pot, coat the lamb in the sauce.
4. Attach the lid and secure, select MEAT and cook under pressure for 1 hour.
5. When the cooking time has finished, remove the lamb shanks and place them on a large serving plate and keep them warm.
6. Add a squeeze of lemon juice, a drizzle of honey and add the chickpeas.
7. Select the SAUTÉ function and bring the liquid to a boil, simmer down until the sauce has thickened.
8. Pour the sauce over the lamb shanks and serve with cous cous.

Recipes

Asian Style Aromatic Pulled Pork

This is the perfect recipe for the pressure cooker; it produces meltingly tender meat in 70 minutes. Fabulous for a party, simply prepare everything in advance and just let the pressure cooker do all the work. The pork does benefit from marinating in the spice rub overnight.

Serves 6-8

Ingredients

- 2.5 kg pork shoulder, remove rind and fat

Sauce

- 1-2 tbsp. vegetable oil
- 1 onion, peeled and sliced into thick rings
- 2 tbsp. light soy sauce
- 3 tbsp. hoisin sauce
- 2 tbsp. rice vinegar or cider vinegar
- 8 tbsp. water
- 1 tbsp. runny honey

Spice rub

- 1 tbsp. sugar
- 1 star anise
- 1 tsp. fennel seeds
- 1 tsp. Szechuan peppercorns
- 1 cinnamon stick
- 1 tsp. coriander seeds
- 1 tsp. ground ginger
- 1 tsp. garlic salt
- 2 cloves

Serve with tortilla wraps, strips of cucumber and spring onion

Method

1. Remove the rind from the pork and remove as much fat using a sharp knife as you can. Cut the pork into 4 large pieces, set aside for a minute.
2. Make the spice rub by blitzing the ingredients in a spice grinder or pounding with a pestle and mortar, until you have a powder. Using your hands rub this into the pieces of pork then place in a bowl and cover with cling film. Marinate this overnight in the fridge if you can, if not as long as possible.
3. When ready to cook, sear the pieces of pork in a little oil on the BROWNING function until brown on all sides, remove from the pot for a minute. Cancel the browning function.
4. Add the onion in a layer on the bottom of the cooking pot and add the soy sauce, hoisin sauce, rice/cider vinegar and water. Sit the pork on top and turn the meat over to coat it in the sauce.
5. Select the MEAT function and increase the time to 70 minutes, cook under pressure. When the pork has finished cooking, release the pressure. Remove the pork from the pot and place on a serving plate and spoon a little of the cooking liquid over it. Leave the meat to rest covered with foil for 10-15 minutes.
6. While the meat is resting, bring the cooking liquid to the boil on the SAUTÉ function and add the honey, leave this to reduce down to a thick consistency. Strain through a sieve if desired.
7. When ready to serve, shred the meat with two forks.
8. Serve the pulled pork piled onto a tortilla wrap with cucumber and spring onion strips and a good drizzle of the sauce, roll up and eat.

Recipes

Celeriac and Stilton Soup

This soup is made using Celeriac which is a very underrated vegetable. The combination of the subtle sweetness from the pear and the creaminess from the Stilton is a real winner.

Serves 4

Ingredients

- Knob of butter
 - 1 large onion, peeled and quartered
 - 500g celeriac, peeled and chopped into small chunks
 - 250g potatoes, peeled and chopped
 - 1 ripe pear, peeled, cored and diced
 - Few sprigs of thyme
 - Sea salt and freshly ground black pepper
 - 1 litre vegetable stock
 - 125g Stilton, crumbled
- Serve with crusty bread and a swirl of cream

Method

1. Add the butter to the cooking pot and select SAUTÉ, Add the onion and gently fry for 5-6 minutes until softened.
2. Add the celeriac, potato, pear and thyme to the pan with some salt and pepper and add the vegetable stock, switch to the SOUP setting and cook under pressure for 20 minutes. When cooking has finished use the natural release method.
3. Remove the lid and take out any stalks from the thyme. Then blend until smooth using a hand stick blender in the cooking pot, taking care not to scratch the base of the bowl.
4. Stir in half the Stilton and allow to gently melt in the soup.
5. Divide the soup between warm bowls and sprinkle the remaining Stilton over each portion to serve.
6. Serve with a swirl of cream and some warm crusty bread.

Recipes

Beef Shin Ragu

This is comfort food at its best made with a great cheap cut Shin of Beef. The long slow cooking time tenderises the meat and makes it deliciously tender. This thick meaty sauce needs to be served with wide pasta such as pappardelle.

Serves 4-6

Ingredients

- 1 tbsp. oil
 - 1.5 kg shin of beef, sliced into thick pieces
 - 75g pancetta, chopped into small pieces
 - 1 large onion
 - 4 garlic cloves, crushed
 - 2 sticks celery, finely chopped
 - 2 carrots, finely chopped
 - 2 tbsp. tomato puree
 - 3 anchovy fillets
 - 200ml red wine
 - 300ml beef stock
 - Bouquet garni made with thyme, rosemary and bay leaf
- Serve with thick pasta such as pappardelle and shaved parmesan

Method

1. Add the oil to the cooking pot and select the **BROWNING** function, brown the beef on all sides you will have to do this in batches so it does not stew; when brown set aside.
2. Select the **SAUTÉ** function and add a little more oil if needed and sauté the pancetta till crisp, and then add the onion, garlic, celery and carrots and sauté till softened this will take about 10 minutes.
3. Add the tomato puree and the anchovy fillets and cook for a few minutes. Add the wine and bring to a bubble to reduce slightly then add the stock and bouquet garni.
4. Add the beef back to the pan along with any resting juices and switch the unit to **SLOW COOK**. Cook the Ragu for 6-8 hours or until meltingly tender, if you can give it a stir during cooking.
5. After the cooking time has finished, remove the beef and shred with 2 forks, increase the heat to a rapid boil and reduce the sauce to a thick consistency. Add the meat back to the pot and stir through.
6. Serve with hot freshly cooked pappardelle and shaved parmesan cheese.

Recipes

Pot Roast Chicken with Rosemary and Garlic

This is one pot cooking at its best. This recipe cooks a whole chicken in 30 minutes; this means that you can have a mid-week roast in no time at all!

Serves 4-6 people depending on how hungry you are!

Ingredients

- 1 tbsp. finely chopped fresh rosemary, plus a few extra sprigs
 - 30g soft butter
 - 1 lemon, zested
 - 2-3 garlic cloves
 - 1 tsp. sea salt
 - freshly ground black pepper
 - 1 medium size chicken (approximately 1.5kg)
 - 1 small glass of dry white wine or chicken stock
 - 2 onions, peeled and thickly sliced
 - 1 tbsp. cornflour/water mixture to thicken
- Serve with a selection of vegetables or a simple salad.

Method

1. **Start by making the herb butter.** Pound the chopped rosemary, butter, lemon zest, garlic, salt and a good grind of black pepper in a mortar and pestle until it is smooth or you could use a mini chopper.
2. **The aim is to get the butter under the skin of the chicken, so lift the skin slightly and using your fingers loosen the skin from the chicken breast, this creates a 'pocket' for you to add the butter.** Spoon in some of the butter and push it down and around the breast. Repeat with the other side. Keep a little back and rub it all over the chicken.
3. **Slice the lemon in half and add half to the cavity of the chicken along with a sprig of rosemary.**
4. **Use the BROWNING function to sear your chicken on all sides; this will give the chicken some colour when cooked. When browned on all sides remove and set this aside for a minute. Cancel the browning function.**
5. **Add the sliced onions so that they fit in the bottom of the cooking pot. Add the wine or stock to the cooking pot and the last sprig of rosemary to the cooking liquid. Place the chicken on top of the onions, by doing this the chicken does not come into contact with the base where the skin can catch slightly and the onions will add a lovely flavour to the gravy.**
6. **Give the chicken another sprinkle with salt and pepper and a sprinkle with any stray bits of rosemary and secure the lid.**
7. **Select the CHICKEN function and set the time to 30 minutes. Cook under pressure. When the chicken has finished cooking, leave the unit for 10 minutes to give the chicken time to rest. Release any remaining pressure and remove the chicken. If you want to brown it further pop it under a hot grill for 5 minutes to crisp the skin.**
8. **Skim any fat away from the juice remaining in the cooking pot and thicken the remaining liquid with the cornflour/water mixture or reduce it down by bringing it back to the boil on the SAUTÉ function and bubble away until reduced, strain through a sieve and serve with the chicken.**

Recipes

Chicken with Chorizo

This dish is a delicious combination of chicken with smoky chorizo; make sure you have lots of crusty bread to mop up the rich sauce.

Serves 4-6

Ingredients

- 1 tsp. oil
- 8 skinless and boneless chicken thighs, chopped into bite size pieces
- 1 chorizo ring, chopped into bite size pieces
- 2 x red onions, diced
- 2 x garlic cloves
- 2 red peppers, de-seeded and roughly chopped
- 2 sticks celery, sliced
- 1.5 tsp. hot chilli powder
- 1 x 400g tin of cherry tomatoes
- 100ml chicken stock
- 1 x 400g tin of Borlotti beans
- 1 tbsp. chopped parsley

Method

1. Add the oil to the pot and select the **BROWNING** function. Add the chicken pieces and brown on all sides. Remove and set aside for a minute.
2. Select **SAUTÉ**; add the chorizo pieces and cook until crispy, then add the onion and garlic and sauté in the oil from the chorizo until softened slightly.
3. Add the add peppers, celery and the chilli powder and stir for 1 minute. Add the chicken back into the cooking pot and add the cherry tomatoes and stock and stir well. Change the setting to the **CHICKEN** function and cook for 15 minutes under pressure.
4. When the cooking time has finished, add the beans and parsley replace the lid and leave to stand for 5 minutes to heat the beans through.
5. Serve with crusty bread or rice.

Recipes

South Indian Vegetable Curry with Paneer

This curry is lightly spiced and lovely and fragrant, the addition of Paneer gives the curry more body, serve it with warm naan bread to soak up the sauce.

Serves 4-5

Ingredients

- 2 tbsp. vegetable oil
- 1 large onion sliced
- 2 tsp. peeled and grated ginger
- 2 garlic cloves, crushed
- 2 tsp. black mustard seeds
- 12-15 fresh curry leaves
- 1 tsp. ground cumin
- 2 tsp. garam masala
- 1 tsp. turmeric
- 1/4 tsp. cracked black pepper
- 1 green chilli, finely chopped
- 400ml coconut milk
- 150ml vegetable stock
- 2 carrots, peeled and diced into big chunks
- 1 small head of cauliflower, broken into florets
- 2 courgettes, chopped into chunky pieces
- 1 large sweet potato, peeled and chopped into chunky pieces
- 200g green beans, trimmed and sliced in half
- 227g block Paneer cheese, cubed into bite size pieces
- 100g baby spinach leaves
- Small bunch coriander, chopped

Serve with warm naan bread, basmati rice and lemon wedges

Method

1. Add the oil to the cooking pot and select the SAUTÉ function add the sliced onion and fry until softened but not coloured, add the ginger, garlic, spices, and chilli and fry until fragrant.
2. Add the coconut milk and stock and bring to the boil. Stir in the carrot, cauliflower, courgettes, sweet potato, green beans and paneer and stir well to coat everything in the sauce. Cancel the SAUTÉ function.
3. Place the lid onto the unit and select PRESSURE, set it to 5 minutes. Cook under pressure.
4. When cooking has finished, release the steam straight away and remove the lid carefully away from you.
5. Add spinach and chopped coriander and stir into the curry. Replace the lid and leave to sit for 2-3 minutes to allow the spinach to wilt.
7. Serve the curry with warm naan bread and scattered with a little more chopped coriander.

Recipes

Hearty Winter Soup with Ham Hock

This soup is delicious in the cold winter months and is substantial enough for a main meal. It is thick and wholesome with exceptionally tender meat.

Serves 6

Ingredients

- 1 unsmoked bacon/ham hock
- 2 carrots, peeled and chopped
- 2 celery sticks, chopped
- 1 onion, chopped
- 150g dried red lentils
- 150g dried yellow split peas
- 80g pearl barley
- 1 tbsp. mixed herbs
- 1.5 litres hot chicken stock
- Freshly ground black pepper

Serve with crusty bread and butter

Method

1. Prepare the bacon/ham hock by removing the rind and as much fat as possible using a sharp knife.
2. Place the bacon/ham hock into the cooking pot.
3. Add the remaining ingredients, make sure the liquid does not exceed the half way mark and stir well.
4. Replace the lid and select the SOUP setting increase the time to 80 minutes.
5. When the cooking time has finished cooking. Leave the unit to release the pressure naturally; this should take about 10-15 minutes, only release the lid with the pressure goes down.
6. Remove the ham hock and cut into big chunks and add back to the soup, give it a stir.
7. Serve in soup bowls with crusty bread on the side.
8. Any left overs can be frozen in soup pouches and kept for 3 months.

Recipes

Perfect Mash Potato

This has got to be one of the best ways to cook potatoes; steaming retains all the nutrients and keeps them dry which makes fantastic creamy mash potato.

Serves 4

Ingredients

- 1kg Maris Piper potatoes evenly sized, washed and left whole
- Knob of Butter
- Splash of Milk/Cream
- Sea salt and freshly ground pepper

Method

1. **Scrub the potatoes well.**
2. **Fill the cooking pot with water to the 1/5 level on the inside of the pot and place the steaming rack inside the pot.**
3. **Place the potatoes on top of the steaming rack and secure the lid.**
4. **Select the STEAM option and cook under pressure for 15 minutes.**
5. **When cooking has finished release the pressure and using a knife remove the skin from the potatoes, taking care as the potatoes will be very hot!**
6. **Place the potatoes in a bowl add a knob of butter and a good splash of milk or cream.**
7. **Mash the potatoes until smooth and season generously with salt and pepper. For other delicious options, add grated cheese, wholegrain mustard or even a dollop of creamed horseradish sauce.**

Recipes

Boston Style Baked Beans

This is a fantastic side dish perfect with sausages and mashed potato or a perfect side dish for a gang when having a BBQ!

Serves 6-8

Ingredients

- 500g dried haricot beans, rinsed and picked over to remove any broken beans
- 2 tsp. salt
- 1 tbsp. oil
- 2 litre water
- 100g treacle
- 130g tomato ketchup
- 40g dark brown sugar
- 2 tbsp. wholegrain mustard
- 1 tsp. dry mustard powder
- 1 tbsp. balsamic vinegar
- 1/2 tsp. salt
- 1/4 tsp. ground black pepper
- 1/2 tsp. chilli powder
- 700ml water

For the Sauce

- 1 tbsp. oil
- 180g smoked bacon lardons
- 1 large onion, chopped

Method

1. Use a quick soak method to cut down on soaking time for the beans, to do this place the beans, salt, oil and water into the cooking pot and secure the lid. Select the **PRESSURE** setting and cook under pressure for 4 minutes, then use the quick release method to release the pressure. Drain the beans and set them aside.
2. Wipe out the cooking pot and replace into the unit, add the oil and bacon lardons and use the **SAUTÉ** function to crisp the bacon, when the bacon is crisp add the onion and cook until softened then cancel the setting.
3. Add the remaining ingredients to the cooking pot and all of the drained beans, give it a good stir and secure the lid. Cook on the **PRESSURE** setting for 45 minutes.
4. When cooking has finished release the pressure, the beans should be tender but not too soft and still have a slight bite to them, if they are too firm, cook for a further 5 minutes.



www.bellahousewares.co.uk



facebook.com/BellaLifeUK



twitter.com/BellaLifeUK



pinterest.com/bellalifeuk/



instagram.com/bellalifeuk

[#mybellalifeuk](https://twitter.com/BellaLifeUK)

MPL Home Ltd, HP2 7DX

SZ-312824

The JS-44 civil cover sheet and the information contained herein neither replace nor supplement the filing and service of pleadings or other papers as required by law, except as provided by local rules of court. This form, approved by the Judicial Conference of the United States in September 1974, is required for use of the Clerk of Court for the purpose of initiating the civil docket sheet.

PLAINTIFFS
DR. JOHN THOMAS FRIEDLAND

DEFENDANTS
SENSIO, INC.

ATTORNEYS (FIRM NAME, ADDRESS, AND TELEPHONE NUMBER)
Randi Kassan, Esq. MILBERG COLEMAN BRYSON PHILLIPS
GROSSMAN, LLC: 100 Garden City Plaza, Suite 500, Garden City, NY
11530. Telephone: (516) 741-5600

ATTORNEYS (IF KNOWN)

CAUSE OF ACTION (CITE THE U.S. CIVIL STATUTE UNDER WHICH YOU ARE FILING AND WRITE A BRIEF STATEMENT OF CAUSE)
(DO NOT CITE JURISDICTIONAL STATUTES UNLESS DIVERSITY)

28 U.S.C. § 1332 ;Products Liability action involving a defective pressure cooker

Has this action, case, or proceeding, or one essentially the same been previously filed in SDNY at any time? No Yes Judge Previously Assigned

If yes, was this case Vol. Invol. Dismissed. No Yes If yes, give date _____ & Case No. _____

IS THIS AN INTERNATIONAL ARBITRATION CASE? No Yes

(PLACE AN [x] IN ONE BOX ONLY)

NATURE OF SUIT

TORTS		ACTIONS UNDER STATUTES			
CONTRACT	PERSONAL INJURY	PERSONAL INJURY	FORFEITURE/PENALTY	BANKRUPTCY	OTHER STATUTES
[] 110 INSURANCE	[] 310 AIRPLANE	[] 367 HEALTHCARE/ PHARMACEUTICAL PERSONAL	[] 625 DRUG RELATED	[] 422 APPEAL	[] 375 FALSE CLAIMS
[] 120 MARINE	[] 315 AIRPLANE PRODUCT LIABILITY	[] INJURY/PRODUCT LIABILITY	[] SEIZURE OF PROPERTY	[] 28 USC 158	[] 376 QUI TAM
[] 130 MILLER ACT	[] 320 ASSAULT, LIBEL & SLANDER	[] 365 PERSONAL INJURY PRODUCT LIABILITY	[] 21 USC 881	[] 423 WITHDRAWAL	[] 400 STATE REAPPORTIONMENT
[] 140 NEGOTIABLE INSTRUMENT	[] 330 FEDERAL EMPLOYERS' LIABILITY	[] 368 ASBESTOS PERSONAL INJURY PRODUCT LIABILITY	[] 690 OTHER	[] 28 USC 157	[] 410 ANTI TRUST
[] 150 RECOVERY OF OVERPAYMENT & ENFORCEMENT OF JUDGMENT	[] 340 MARINE	PERSONAL PROPERTY	PROPERTY RIGHTS	[] 880 DEFEND TRADE SECRETS ACT	[] 430 BANKS & BANKING
[] 151 MEDICARE ACT	[] 345 MARINE PRODUCT LIABILITY	[] 370 OTHER FRAUD	[] 820 COPYRIGHTS	[] 830 PATENT	[] 450 COMMERCE
[] 152 RECOVERY OF DEFAULTED STUDENT LOANS (EXCL VETERANS)	[] 350 MOTOR VEHICLE	[] 371 TRUTH IN LENDING	[] 835 PATENT-ABBREVIATED NEW DRUG APPLICATION	[] 840 TRADEMARK	[] 460 DEPORTATION
[] 153 RECOVERY OF OVERPAYMENT OF VETERAN'S BENEFITS	[] 355 MOTOR VEHICLE PRODUCT LIABILITY	[] 380 OTHER PERSONAL PROPERTY DAMAGE	LABOR	SOCIAL SECURITY	[] 470 RACKETEER INFLU- ENCED & CORRUPT ORGANIZATION ACT (RICO)
[] 160 STOCKHOLDERS SUITS	[] 360 OTHER PERSONAL INJURY	[] 385 PROPERTY DAMAGE PRODUCT LIABILITY	[] 710 FAIR LABOR STANDARDS ACT	[] 861 HIA (1395ff)	[] 480 CONSUMER CREDIT
[] 190 OTHER CONTRACT	[] 362 PERSONAL INJURY - MED MALPRACTICE	PRISONER PETITIONS	[] 720 LABOR/MGMT RELATIONS	[] 862 BLACK LUNG (923)	[] 485 TELEPHONE CONSUMER PROTECTION ACT
[] 195 CONTRACT PRODUCT LIABILITY	ACTIONS UNDER STATUTES	[] 463 ALIEN DETAINEE	[] 740 RAILWAY LABOR ACT	[] 863 DIWC/DIWW (405(g))	[] 490 CABLE/SATELLITE TV
[] 196 FRANCHISE	CIVIL RIGHTS	[] 510 MOTIONS TO VACATE SENTENCE	[] 751 FAMILY MEDICAL LEAVE ACT (FMLA)	[] 864 SSID TITLE XVI	[] 495 SECURITIES/ COMMODITIES/ EXCHANGE
	[] 440 OTHER CIVIL RIGHTS (Non-Prisoner)	[] 530 HABEAS CORPUS	[] 790 OTHER LABOR LITIGATION	[] 865 RSI (405(g))	[] 890 OTHER STATUTORY ACTIONS
REAL PROPERTY	[] 441 VOTING	[] 535 DEATH PENALTY	[] 791 EMPL RET INC SECURITY ACT (ERISA)	FEDERAL TAX SUITS	[] 891 AGRICULTURAL ACTS
[] 210 LAND CONDEMNATION	[] 442 EMPLOYMENT	[] 540 MANDAMUS & OTHER	IMMIGRATION	[] 870 TAXES (U.S. Plaintiff or Defendant)	[] 893 ENVIRONMENTAL MATTERS
[] 220 FORECLOSURE	[] 443 HOUSING/ ACCOMMODATIONS	PRISONER CIVIL RIGHTS	[] 462 NATURALIZATION APPLICATION	[] 871 IRS-THIRD PARTY	[] 895 FREEDOM OF INFORMATION ACT
[] 230 RENT LEASE & EJECTMENT	[] 445 AMERICANS WITH DISABILITIES - EMPLOYMENT	[] 550 CIVIL RIGHTS	[] 465 OTHER IMMIGRATION ACTIONS	[] 26 USC 7609	[] 896 ARBITRATION
[] 240 TORTS TO LAND	[] 446 AMERICANS WITH DISABILITIES -OTHER	[] 555 PRISON CONDITION			[] 899 ADMINISTRATIVE PROCEDURE ACT/REVIEW OR APPEAL OF AGENCY DECISION
[] 245 TORT PRODUCT LIABILITY	[] 448 EDUCATION	[] 560 CIVIL DETAINEE CONDITIONS OF CONFINEMENT			[] 950 CONSTITUTIONALITY OF STATE STATUTES
[] 290 ALL OTHER REAL PROPERTY					

Check if demanded in complaint:

CHECK IF THIS IS A CLASS ACTION UNDER F.R.C.P. 23

DO YOU CLAIM THIS CASE IS RELATED TO A CIVIL CASE NOW PENDING IN S.D.N.Y. AS DEFINED BY LOCAL RULE FOR DIVISION OF BUSINESS 13? IF SO, STATE:

DEMAND \$400,000.00 OTHER _____ JUDGE Jennifer Rochon DOCKET NUMBER 1:22-cv-10554

Check YES only if demanded in complaint
JURY DEMAND: YES NO

NOTE: You must also submit at the time of filing the Statement of Relatedness form (Form IH-32).

(PLACE AN x IN ONE BOX ONLY)

ORIGIN

- 1 Original Proceeding, 2 Removed from State Court, 3 Remanded from Appellate Court, 4 Reinstated or Reopened, 5 Transferred from (Specify District), 6 Multidistrict Litigation (Transferred), 7 Appeal to District Judge from Magistrate Judge, 8 Multidistrict Litigation (Direct File), a. all parties represented, b. At least one party is pro se.

(PLACE AN x IN ONE BOX ONLY)

BASIS OF JURISDICTION

IF DIVERSITY, INDICATE CITIZENSHIP BELOW.

- 1 U.S. PLAINTIFF, 2 U.S. DEFENDANT, 3 FEDERAL QUESTION, 4 DIVERSITY (U.S. NOT A PARTY)

CITIZENSHIP OF PRINCIPAL PARTIES (FOR DIVERSITY CASES ONLY)

(Place an [X] in one box for Plaintiff and one box for Defendant)

Table with columns for Plaintiff (PTF) and Defendant (DEF) citizenship in various states and countries.

PLAINTIFF(S) ADDRESS(ES) AND COUNTY(IES) Little Rock, County of Pulaski, Arkansas

DEFENDANT(S) ADDRESS(ES) AND COUNTY(IES) 261 Madison Avenue, 25th Floor, New York, NY 100168

DEFENDANT(S) ADDRESS UNKNOWN

REPRESENTATION IS HEREBY MADE THAT, AT THIS TIME, I HAVE BEEN UNABLE, WITH REASONABLE DILIGENCE, TO ASCERTAIN THE RESIDENCE ADDRESSES OF THE FOLLOWING DEFENDANTS:

COURTHOUSE ASSIGNMENT

I hereby certify that this case should be assigned to the courthouse indicated below pursuant to Local Rule for Division of Business 18, 20 or 21.

Check one: THIS ACTION SHOULD BE ASSIGNED TO: [] WHITE PLAINS [x] MANHATTAN

DATE 2/19/2024 /S/ RANDI KASSAN SIGNATURE OF ATTORNEY OF RECORD

ADMITTED TO PRACTICE IN THIS DISTRICT [] NO [x] YES (DATE ADMITTED Mo. Nov. Yr. 2006) Attorney Bar Code # 4375754

RECEIPT #

Magistrate Judge is to be designated by the Clerk of the Court.

Magistrate Judge _____ is so Designated.

Ruby J. Krajick, Clerk of Court by _____ Deputy Clerk, DATED _____.

UNITED STATES DISTRICT COURT (NEW YORK SOUTHERN)

AO 440 (Rev. 06/12) Summons in a Civil Action

UNITED STATES DISTRICT COURT

for the

Southern District of New York

DR. JOHN THOMAS FRIEDLAND

Plaintiff(s)

v.

SENSIO, INC.

Defendant(s)

Civil Action No. 1:24-cv-01216

SUMMONS IN A CIVIL ACTION

To: (Defendant's name and address) SENSIO, INC.
C/O C T CORPORATION SYSTEM
28 LIBERTY STREET, NEW YORK, NY, UNITED STATES, 10005

A lawsuit has been filed against you.

Within 21 days after service of this summons on you (not counting the day you received it) — or 60 days if you are the United States or a United States agency, or an officer or employee of the United States described in Fed. R. Civ. P. 12 (a)(2) or (3) — you must serve on the plaintiff an answer to the attached complaint or a motion under Rule 12 of the Federal Rules of Civil Procedure. The answer or motion must be served on the plaintiff or plaintiff's attorney, whose name and address are: Randi Kassan, Esq. MILBERG COLEMAN BRYSON PHILLIPS GROSSMAN, LLC 100 Garden City Plaza Suite 500 Garden City, NY 11530

If you fail to respond, judgment by default will be entered against you for the relief demanded in the complaint. You also must file your answer or motion with the court.

CLERK OF COURT

Date:

Signature of Clerk or Deputy Clerk

Civil Action No. _____

PROOF OF SERVICE

(This section should not be filed with the court unless required by Fed. R. Civ. P. 4 (l))

This summons for *(name of individual and title, if any)* _____
was received by me on *(date)* _____ .

I personally served the summons on the individual at *(place)* _____
_____ on *(date)* _____ ; or

I left the summons at the individual's residence or usual place of abode with *(name)* _____
_____, a person of suitable age and discretion who resides there,
on *(date)* _____ , and mailed a copy to the individual's last known address; or

I served the summons on *(name of individual)* _____ , who is
designated by law to accept service of process on behalf of *(name of organization)* _____
_____ on *(date)* _____ ; or

I returned the summons unexecuted because _____ ; or

Other *(specify)*: _____

My fees are \$ _____ for travel and \$ _____ for services, for a total of \$ _____ 0.00 _____ .

I declare under penalty of perjury that this information is true.

Date: _____

Server's signature

Printed name and title

Server's address

Additional information regarding attempted service, etc: